

**PRODUCT DETAILS**

<b>PRODUCT CODE</b>	MFN150L-4D	
<b>CHARACTERISTIC</b>	Sealed Maintenance Free (SMF) Lead Acid Battery	
<b>GROUP SIZE</b>	N150	
<b>CASE AND LID</b>	Material : Polypropylene (PP)	
	Handle : 2-pc rope handle	
	Ledge : No ledge	
	Vent : Centralised venting	<b>24 Months Warranty*</b>

**DIMENSIONAL SPECIFICATIONS**

OVERALL DIMENSIONS	METRIC (mm)
<b>LENGTH</b>	513
<b>WIDTH</b>	221
<b>HEIGHT (bottom to top cover)</b>	195
<b>TOTAL HEIGHT (bottom to top of terminal)</b>	223
<b>APPROXIMATE WEIGHT, kg</b>	48.8

TERMINAL DATA	POSITIVE	NEGATIVE
<b>TYPE</b>	SAE	SAE
<b>TERMINAL HEIGHT (mm)</b>	18+/- 1	18+/- 1
<b>BOTTOM DIAMETER (mm)</b>	19.5 -0.3	17.9 -0.3
<b>TAPER</b>	1:9	1:9
<b>POLARITY</b>	E (Positive Left)	

**CAPACITY SPECIFICATIONS**

<b>COLD CRANKING AMPS (CCA) SAE CCA</b>	1400 CCA
	Test reference: AS60095:2022 Rated CCA DCH at 18°C for 30 sec
<b>AMPERE-HOUR AT 20-HOUR CAPACITY</b>	180 Ah
	Test reference: AS60095:2022 Rated AH DCH at 10.5 V cut-off voltage

<b>RESERVE CAPACITY TEST</b>	370 min
	Test reference: AS60095:2022 25Amps DCH at 10.5V cut-off voltage

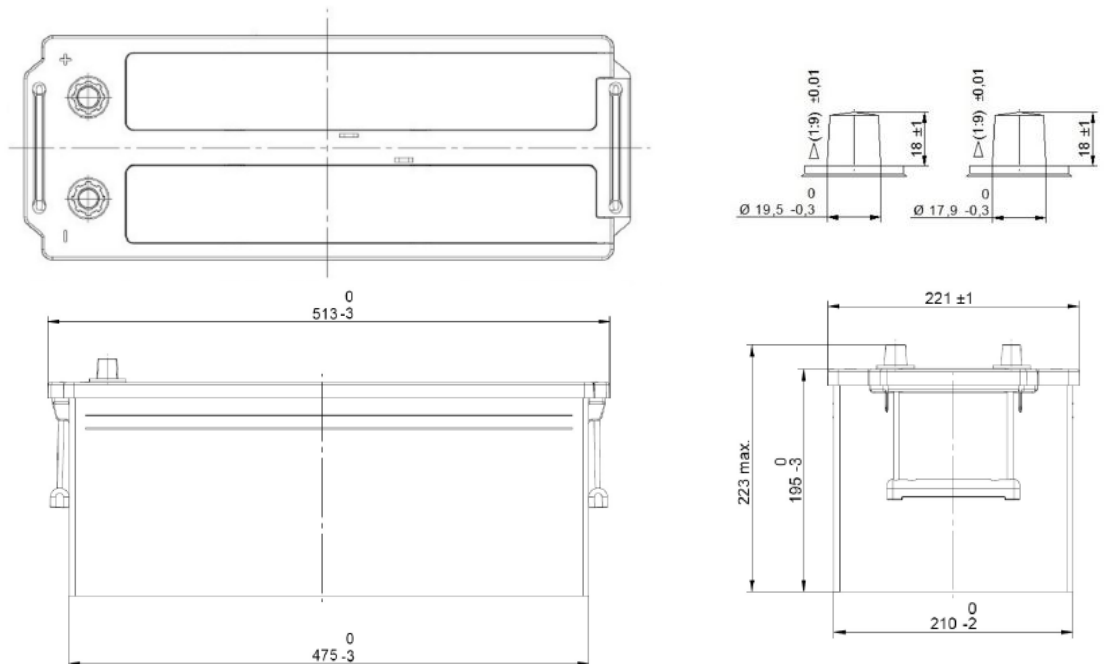

\*Warranty terms and conditions apply